

DSP-1760 FOGs

Single- or Multi-axis, High Performance Fiber Optic Gyros



Housed



Unhoused



Available in 1-, 2-, or 3-axes

Key Features

- Superior bias instability of $\leq 0.05^\circ/\text{hr}$, 1σ (typical); $\leq 0.1^\circ/\text{hr}$, 1σ (max)
- Single- or multi-axis high performance FOGs
- All housed variants available with either Micro-D connector or circular connector
- Unhoused variants available with Micro-D connector
- Angle Random Walk (ARW) $\leq 0.012^\circ/\sqrt{\text{hr}}$ ($0.7^\circ/\text{hr}/\sqrt{\text{Hz}}$)
- Bandwidth (Housed): ≥ 440 Hz
Bandwidth (Unhoused): ≥ 1000 Hz
- Available in nine configurations:
 - Housed 1-, 2-, or 3-axis
 - Unhoused 1-, 2-, or 3-axis tethered to PCBs, with Micro-D connector
- KVH E•Core® ThinFiber technology

Applications

- Platform stabilization for land, sea, and aerial systems
- Navigation, guidance, and control systems
- Stabilization and navigation for unmanned and manned applications

Compact Single- or Multi-axis Fiber Optic Gyros Designed for Maximum Ease of Integration

KVH's DSP-1760 Fiber Optic Gyros (FOGs) combine single- or multi-axes of the world's smallest high performance FOGs within easy-to-integrate housings, or unhoused for OEM configurations. The DSP-1760 FOG offers exceptional performance in bias stability, scale factor, and angle random walk, and is available in nine configurations to solve the most challenging design projects. The DSP-1760 FOG is ideal for air, land, or maritime stabilization and pointing applications. Due to its versatility, and accurate, reliable output, it can also be utilized in navigation, guidance, and control systems.

Designed for Flexibility and Performance

Available in single- or multi-axis gyro configurations, the DSP-1760 FOG is a high bandwidth, extremely low noise sensor. Using KVH's exclusive E•Core ThinFiber, the world's smallest D-shaped optical fiber, the DSP-1760 FOG offers customers a choice of two interfaces: a Micro-D or a circular connector. In addition, the DSP-1760 FOG integrates magnetic shielding within the gyro housing, providing improved performance in systems with problematic magnetic environments.

Superior Quality and Reliability

KVH is the only U.S. FOG manufacturer that draws its own optical fiber, ensuring consistent quality, guaranteed performance, and stable, reliable turn-on to turn-on bias repeatability in every gyro and gyro system. The DSP-1760 FOG is solid state, with an improved electronics design that provides significant improvements in such critical performance areas as bias stability, ARW, and scale factor non-linearity.

Exclusive Technology

KVH's proprietary polarization maintaining E•Core ThinFiber delivers outstanding precision performance in much smaller size gyros, such as the DSP-1760. By reducing the overall diameter of KVH's standard E•Core fiber to just 170 microns, the resulting E•Core ThinFiber optical circuit dramatically increases the accuracy of our standard size gyros, and produces small gyros that deliver extremely high bandwidth and low noise.



Ideal for the stabilization and orientation of high-speed gimbals, the versatile and lightweight DSP-1760 FOG offers nine configurations for ultimate integration flexibility.



Pipelines deliver massive amounts of crude daily and ensuring safe operation is key. The KVH DSP-1760, coupled to additional sensors, provides these inspection robots with extremely accurate angular data.

KVH DSP-1760 Fiber Optic Gyro

Performance Specifications

Input Rate (max)	±490°/sec
Bias Instability (25°C)	≤0.1°/hr, 1σ (max), ≤0.05°/hr, 1σ (typical)
Bias vs. Temperature (≤1°C/min)	≤1.5°/hr, 1σ (max), ≤1°/hr, 1σ (typical)
Bias Offset (25°C)	±2°/hr
Scale Factor Non-linearity (full rate, 25°C)	≤50 ppm, 1σ
Scale Factor vs. Temperature (≤1°C/min)	≤200 ppm, 1σ (max), ≤100 ppm, 1σ (typical)
Angle Random Walk (25°C)	≤0.012°/√hr (0.7°/hr/√Hz)
Bandwidth (-3 dB)	Housed: ≥440 Hz Unhoused: ≥1000 Hz

Electrical/Mechanical Interface

Initialization Time	≤1.25 secs housed, ≤1.5 secs unhoused
Data Interface	Asynchronous or Synchronous RS-422
Baud Rate	User Selectable 9.6 Kbps to 921.6 Kbps (housed) User Selectable 9.6 kbps to 4147 Kbps (unhoused)
Data Rate	User Selectable 1 to 1000 Hz (housed) User Selectable 1 to 5000 Hz (unhoused)

Physical Specifications

Dimensions - Housed (max)	88.9 mm Dia x 73.7 mm H (3.5" x 2.9")
Dimensions - Unhoused	PCB stack: 81 mm Dia x 24.8 mm H (3.19" x 0.978") (nominal) Gyro sensor: 44.7 mm Dia x 21.8 mm H (1.76" x 0.86")
Weight - Housed (max)	Single-axis: 0.50 kg (1.1 lbs.) Dual-axis: 0.54 kg (1.2 lbs.) 3-axis: 0.60 kg (1.3 lbs.)
Weight - Unhoused (nominal)	PCB stack: 0.11 kg (0.25 lbs.) Gyro sensor: 0.07 kg (0.16 lbs.) Flex cables: 0.0005 kg (0.001 lbs.)
Power Consumption	Single-axis: 6 W (max), 3W (typical) Dual-axis: 7 W (max), 4W (typical) 3-axis: 8 W (max), 5W (typical)
Input Voltage	+9 to +36 VDC

Environmental Specifications

Temperature (operating)	-40°C to +75°C (-40°F to +167°F)
Shock (operating)	25 g, 11 msec, sawtooth
Vibration (operating)	8 g rms, 20-2000 Hz, random

For detailed interface control drawings (ICD) and technical information on this product, please visit www.kvh.com/DSP1760docs

Housed DSP-1760s

Micro-D Connector Option

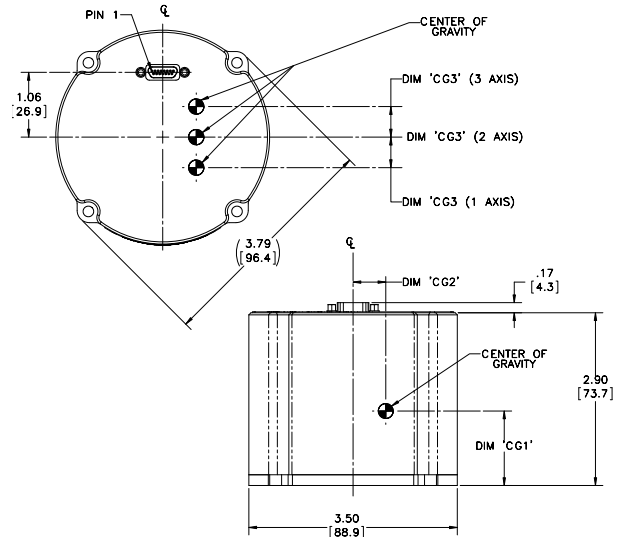

Circular Connector Option

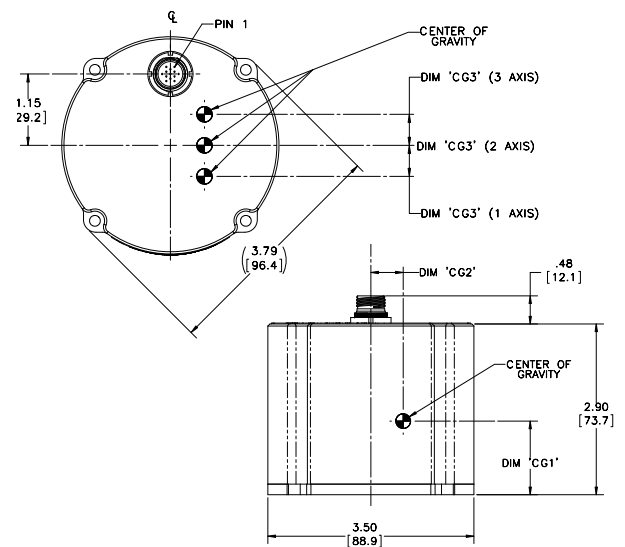

Unhoused DSP-1760s

PCB Stack

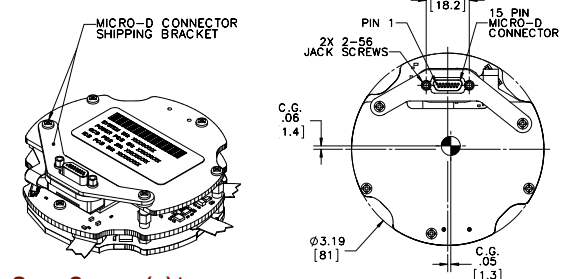

Gyro Sensor(s)*

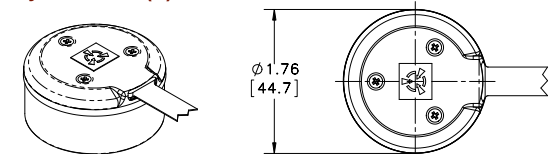

*1, 2, or 3 gyro sensors



KVH Industries, Inc. • 50 Enterprise Center • Middletown, RI 02842 • U.S.A. • Phone: +1 401 847-3327 • Fax: +1 401 845-2410

©2019, KVH Industries, Inc.

Specifications subject to change without notice

KVH and E*Core are registered trademarks of KVH Industries, Inc.

Protected by one or more of the following patents: US 7,317,847, US 6,763,153, US 6,718,097, US 6,707,558, US 6,429,939, US 6,370,289 B1, US 6,134,356, US 6,041,149, US 5,768,462, US 5,739,944, US 5,552,887. Additional patents pending.